



STATIONARY BOOM : SB 17



Standard Features :

- 17 m Boom Length
- Four Legged Chassis
- Three Section Hydraulic Boom
- Remote Control
- End Hose

...sharing knowledge



STATIONARY BOOM SB : 17

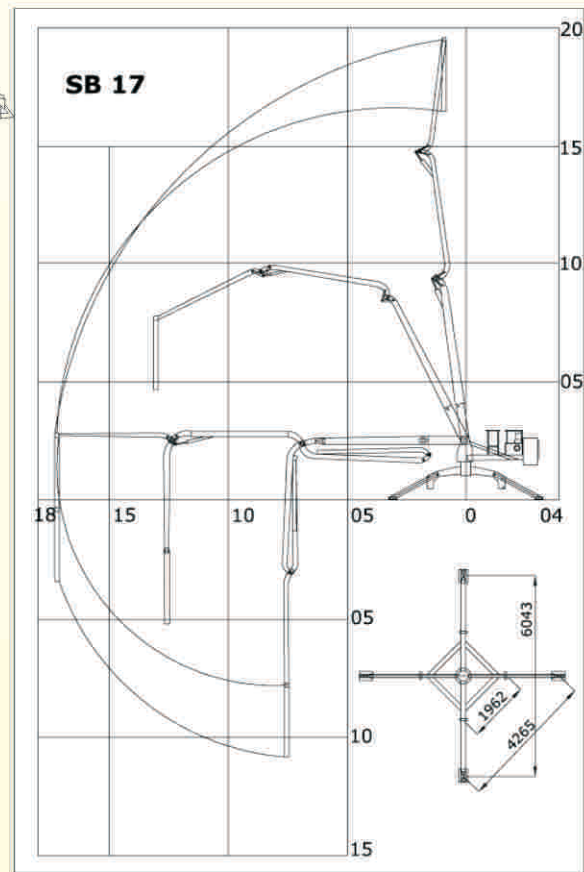
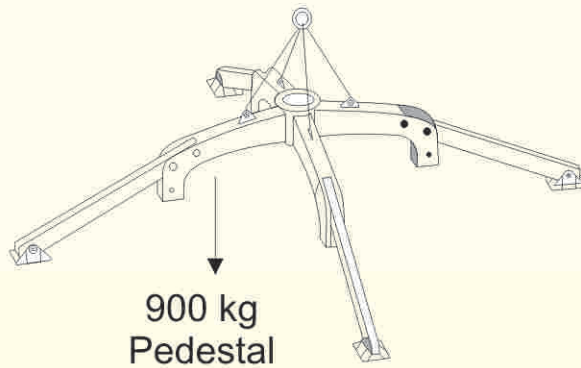
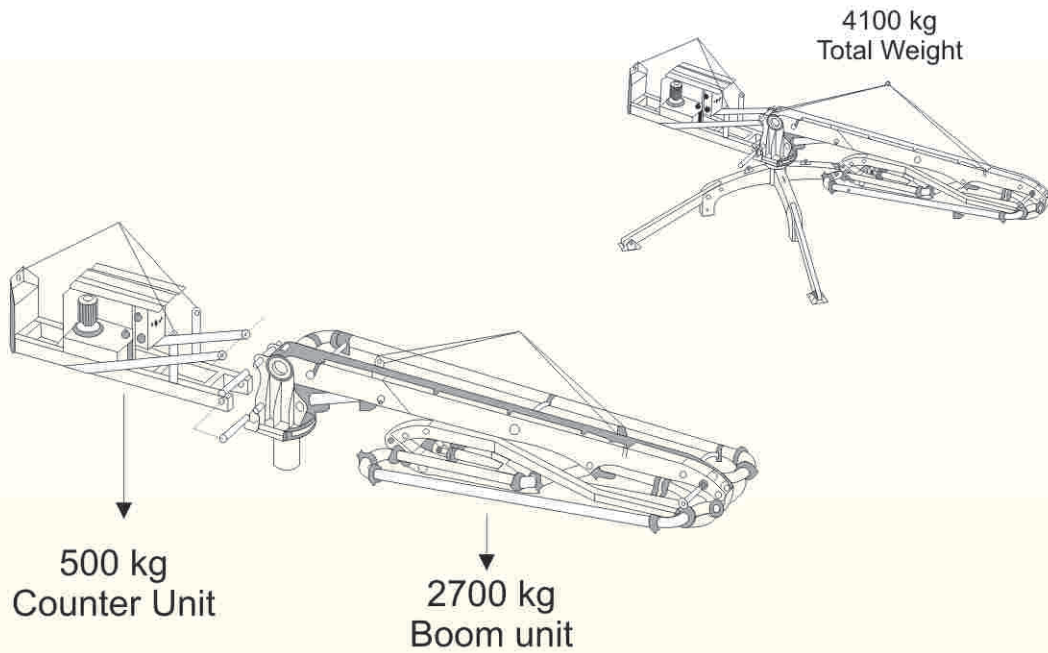

Technical Specifications:

Description		Unit	Data
Boom Type			SB 17
Max. Vertical Reach		mm	19545
Max. Horizontal Reach		mm	17107
Delivery Pipe Diameter		mm	125
Slewing Range		deg	Free Slewing
Each Section Length	1st Arm	mm	6193
	2nd Arm	mm	5594
	3rd Arm	mm	4800
Weight of Machine		kg	4500
Counter Weight		kg	2200
Drive	Electric	kW	7.5
End Hose		m	3

Performance of equipment is based on standard working conditions. Design / Specifications can be changed without prior notice.



AQUARIUS ENGINEERS PVT. LTD.

Concrete Pumps, Batching Plants, Slipform Pavers

'Aquarius House', Sheelavihar Colony, Off Karve Road, Pune 411 038. INDIA
 Tel.: +91 20 2544 5227 Fax: +91 20 2544 5228
 E-mail: info@aquariusengineers.biz Web: www.aquariusengineers.biz

Mfd. by : Putzmeister India Pvt. Ltd.

190, 191, Kundaim Industrial Estate, Ponda, Goa 403 115 India
 Tel.: +91 0832 2396334 Fax.: +91 0832 2396253